

ASSEMBLY AND INSTALLATION INSTRUCTIONS

WARNING: TO AVOID RISK OF ELECTRICAL SHOCK, BE SURE TO SHUT OFF POWER BEFORE INSTALLING OR SERVICING THIS LAMP.

NOTES: 1. Before installing, consult local electrical codes for wiring and grounding requirements.
2. READ AND SAVE THESE INSTRUCTIONS.

PRODUCT SPECIFICATION

A 100% flicker-free LED bulb, compatible with leading-edge and trailing-edge dimmers, close to the spectrum of sunlight, CRI>98, truly restore true colors.
Low energy consumption, long life and simple replacement.

Item name	PREMIUM GU10 8W DIMMABLE
Power	8W
Beam Angle	10D/24D/36D/60D
CCT	2700K/3000K/4000K
LED Life	40.000 hrs
Net Weight	0,071 Kg
Volume	0,00015 m ³
Base / Hole	GU10

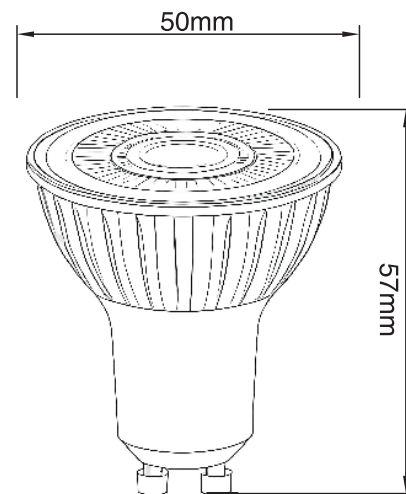

BOX CONTENTS -
1 PCS 8W GU10



ASSEMBLY AND INSTALLATION INSTRUCTIONS

INSTALLATION

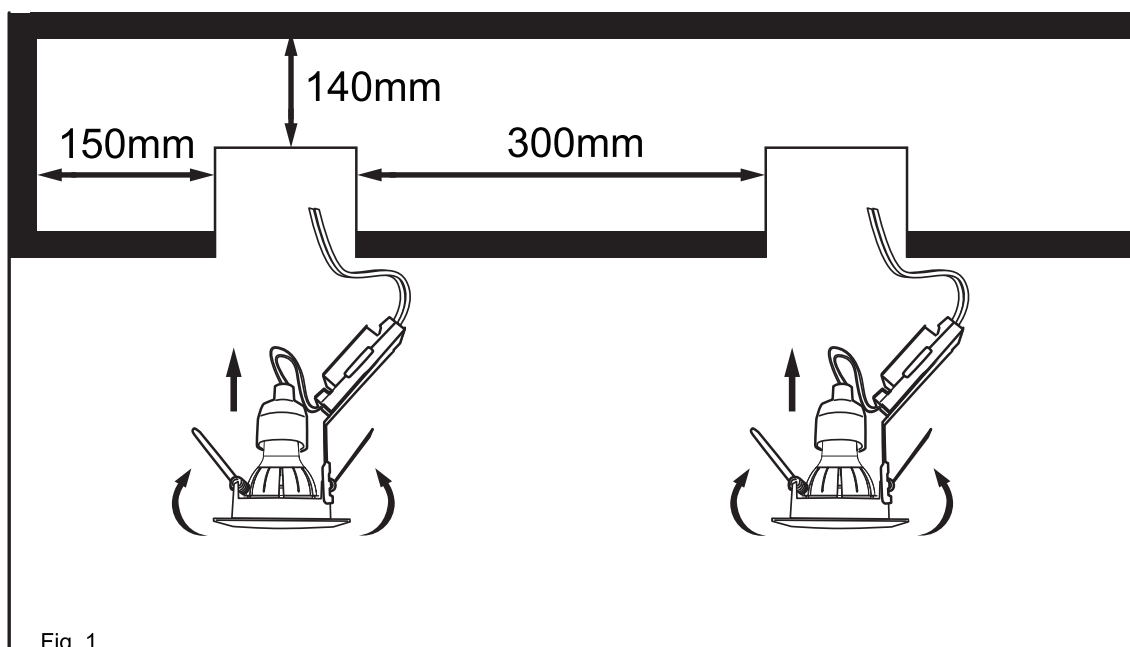

Fig. 1

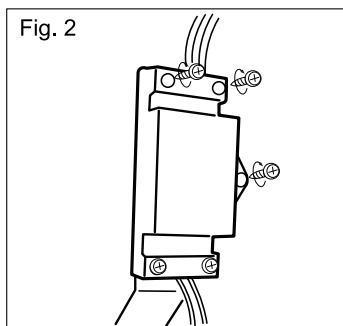

Fig. 2

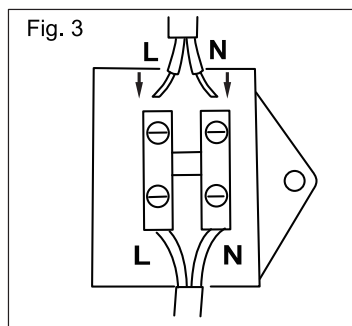

Fig. 3

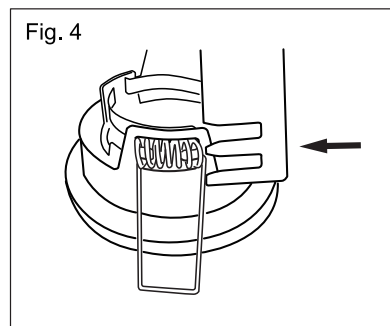

Fig. 4

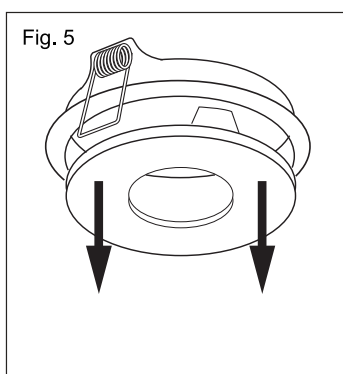

Fig. 5

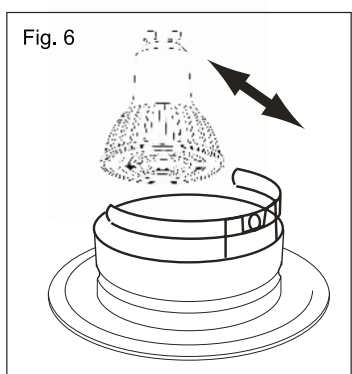

Fig. 6